

# Absolute encoders - bus interfaces

Blind / through hollow shaft or cone shaft (1:10)

CANopen® / 13 bit ST / 16 bit MT / Speed switch

## HMG10 - CANopen®



HMG 10 - picture similar

### Technical data - electrical ratings

Voltage supply	10...30 VDC
Short-circuit proof	Yes
Consumption w/o load	≤200 mA
Initializing time	≤500 ms after power on
Interface	CANopen®
Function	Multiturn
Transmission rate	10...1000 kBaud
Device address	Rotary switch in bus connecting box (type-specific)
Steps per turn	8192 / 13 bit
Number of turns	65536 / 16 bit
Additional outputs	Square-wave HTL/TTL (RS422)
Sensing method	Magnetic
Interference immunity	EN 61000-6-2
Emitted interference	EN 61000-6-3
Programmable parameters	Steps per revolution Number of revolutions Preset, scaling, rotating direction
Diagnostic function	Position or parameter error
Status indicator	DUO-LED in bus connecting box 4 LEDs in device back side
Approvals	CE, UL approval / E256710

### Technical data - electrical ratings (speed switches)

Interface	RS485
Switching accuracy	±2 % (or Digit)
Switching outputs	1 output (Open-Collector or Solid State Relay)
Output switching capacity	30 VDC; ≤100 mA
Switching delay time	≤20 ms

### Features

- Interface CANopen®
- Magnetic sensing method
- Resolution: singleturn 13 bit, multiturn 16 bit
- Function display via LEDs
- Multiturn sensing with Energy Harvesting technologie, without gear or battery
- Two hybrid bearings, one at each end
- Special protection against corrosion C5-M

### Optional

- Integrated speed switch, programmable
- Additional output incremental with zero pulse

### Technical data - mechanical design

Size (flange)	ø105 mm
Flange	Support plate, 360° freely positionable
Protection DIN EN 60529	IP 66/IP 67
Operating speed	≤6000 rpm
Range of switching speed	±2...6000 rpm, default 6000 rpm
Operating torque typ.	10 Ncm
Rotor moment of inertia	950 gcm <sup>2</sup>
Admitted shaft load	≤450 N axial ≤650 N radial
Materials	Housing: aluminium alloy Shaft: stainless steel
Operating temperature	-40...+85 °C
Relative humidity	95 % non-condensing
Resistance	IEC 60068-2-6 Vibration 30 g, 10-2000 Hz IEC 60068-2-27 Shock 400 g, 1 ms
Corrosion protection	IEC 60068-2-52 Salt mist Complies to ISO 12944-5:1998 Protective paint systems (C5-M)
Weight approx.	2.2 kg (depending on version)
Connection	Bus connecting box Terminal box incremental

### HMG10-B - CANopen®

Shaft type	ø16...20 mm (blind hollow shaft) ø17 mm (cone shaft 1:10)
------------	--

### HMG10-T - CANopen®

Shaft type	ø16...20 mm (through hollow shaft)
------------	------------------------------------

# Absolute encoders - bus interfaces

Blind / through hollow shaft or cone shaft (1:10)

CANopen® / 13 bit ST / 16 bit MT / Speed switch

HMG10 - CANopen®

## Part number

Encoder with blind hollow shaft / cone shaft

HMG10 

	-B	H	.			C6	.3		00		.A
--	----	---	---	--	--	----	----	--	----	--	----

Additional output \*

0 Without

See also table "Additional output \*\*"

Resolution multiturn

0 Without

6 16 bit

Voltage supply / interface

C6 10...30 VDC, CANopen® (DS 406)

Connection

5 1x bus connecting box with 3 cable glands M16, radial

1 1x bus connecting box with 2 connectors M12, radial

F 1x bus connecting box with 3 cable glands M16, radial +  
1x terminal box with 1 cable gland M20, radial

Z 1x bus connecting box with 2 connectors M12, radial +  
1x terminal box with 1 cable gland M20, radial

Shaft diameter

6 ø16 mm, central screw

7 ø17 mm cone 1:10, central screw

Z ø20 mm, central screw

Protection

D IP 66 and IP 67, optimized for dusty environments

L IP 66 and IP 67, optimized for oily and wet environments

Flange

H Support for torque arm, shaft insulation hybrid bearing

Speed switch / Programming

Without

D With speed switch \*

(Standard: Open Collector, Solid State Relais on request)

\* Only for connection F or Z

# Absolute encoders - bus interfaces

Blind / through hollow shaft or cone shaft (1:10)

CANopen® / 13 bit ST / 16 bit MT / Speed switch

## HMG10 - CANopen®

### Part number

Encoder with through hollow shaft

HMG10 

	-T	H	.			C6	.3		00		.A
--	----	---	---	--	--	----	----	--	----	--	----

Additional output \*  
0 Without  
See also table "Additional output \*\*"

Resolution multiturn  
0 Without  
6 16 bit

Voltage supply / interface  
C6 10...30 VDC, CANopen® (DS 406)

Connection  
5 1x bus connecting box with 3 cable glands M16, radial  
1 1x bus connecting box with 2 connectors M12, radial  
F 1x bus connecting box with 3 cable glands M16, radial +  
1x terminal box with 1 cable gland M20, radial  
Z 1x bus connecting box with 2 connectors M12, radial +  
1x terminal box with 1 cable gland M20, radial

Shaft diameter  
C ø16 mm, clamping ring on drive side  
F ø20 mm, clamping ring on drive side  
P ø16 mm, clamping ring on drive side with keyway

Protection  
D IP 66 and IP 67, optimized for dusty environments  
L IP 66 and IP 67, optimized for oily and wet environments

Flange  
H Support for torque arm, shaft insulation hybrid bearing

Speed switch / Programming  
Without  
D With speed switch \*  
(Standard: Open Collector, Solid State Relais on request)

\* Only for connection F or Z

# Absolute encoders - bus interfaces

## Blind / through hollow shaft or cone shaft (1:10)

### CANopen® / 13 bit ST / 16 bit MT / Speed switch

## HMG10 - CANopen®

### Part number - tables

#### Additional output \*

0	(Without)
Q	(8192 ppr TTL/HTL push-pull (Vin=Vout), 6 channels)
P	(8192 ppr TTL (RS422), 6 channels)
G	(5000 ppr TTL/HTL push-pull (Vin=Vout), 6 channels)
H	(5000 ppr TTL (RS422), 6 channels)
K	(4096 ppr TTL/HTL push-pull (Vin=Vout), 6 channels)
J	(4096 ppr TTL (RS422), 6 channels)
7	(3072 ppr TTL/HTL push-pull (Vin=Vout), 6 channels)
8	(3072 ppr TTL (RS422), 6 channels)
9	(2048 ppr TTL/HTL push-pull (Vin=Vout), 6 channels)
4	(2048 ppr TTL (RS422), 6 channels)
5	(1024 ppr TTL/HTL push-pull (Vin=Vout), 6 channels)
6	(1024 ppr TTL (RS422), 6 channels)
1	(512 ppr TTL/HTL push-pull (Vin=Vout), 6 channels)
2	(512 ppr TTL (RS422), 6 channels)

\* Only for connection F or Z

### Accessories

#### Mounting accessories

11043628	Torque arm M6, length 67-70 mm
11004078	Torque arm M6, length 120-130 mm (≥71 mm)
11002915	Torque arm M6, length 425-460 mm (≥131 mm)
11054917	Insulated torque arm M6, length 67-70 mm
11072795	Insulated torque arm M6, length 120-130 mm (≥71 mm)
11082677	Insulated torque arm M6, length 425-460 mm (≥131 mm)
11077197	Mounting kit for torque arm size M6 and earthing strap
11077087	Mounting and dismounting set

# Absolute encoders - bus interfaces

Blind / through hollow shaft or cone shaft (1:10)

CANopen® / 13 bit ST / 16 bit MT / Speed switch

## HMG10 - CANopen®

### CANopen® - Terminal assignment

View A<sup>1)</sup> - View inside bus cover

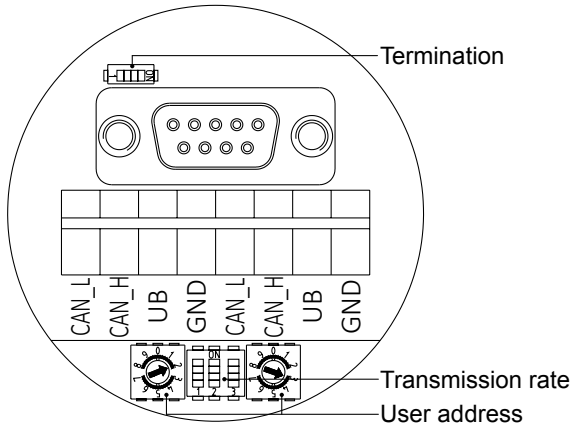

View C<sup>1)</sup> / View D<sup>1)</sup> - View into connector

male / female	Connection	Description
1	GND	Ground for UB
2	UB	Voltage supply 10...30 VDC
3	GND	Ground for UB
4	CAN_H	CAN Bus signal (dominant HIGH)
5	CAN_L	CAN Bus signal (dominant LOW)

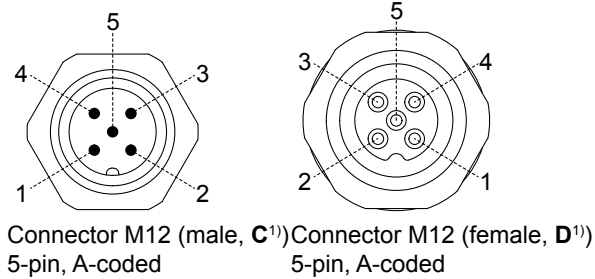

Terminals of the same significance are internally connected and identical in their functions. Max. load on the internal terminal connections UB-UB and GND-GND is 1 A each.

### CANopen® - Features

Bus protocol	CANopen®
CANopen®-Features	Device Class 2 CAN 2.0B
Device profile	CANopen® CiA DSP 406, V 3.0
Operating mode	Polling mode (asynch, via SDO) Cyclic mode (asynch-cyclic) Synch mode (synch-cyclic) Acyclic mode (synch-acyclic)
Diagnosis	The encoder supports the following error warnings: - Position error
Default settings	User address 00

### CANopen® - Termination

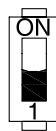

ON = final user  
OFF = user x

### CANopen® - User address

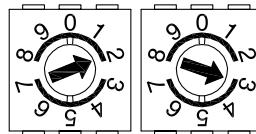

Defined by rotary switch.  
Example: User address 23

### CANopen® - Transmission rate

Transmission rate	Dip switch position		
	1	2	3
10 kBaud	OFF	OFF	OFF
20 kBaud	OFF	OFF	ON
50 kBaud*	OFF	ON	OFF
125 kBaud	OFF	ON	ON
250 kBaud	ON	OFF	OFF
500 kBaud	ON	OFF	ON
800 kBaud	ON	ON	OFF
1000 kBaud	ON	ON	ON

\* Default

<sup>1)</sup> See dimensions

# Absolute encoders - bus interfaces

Blind / through hollow shaft or cone shaft (1:10)

CANopen® / 13 bit ST / 16 bit MT / Speed switch

## HMG10 - CANopen®

### Speed switch/incremental - Terminal significance

+UB	Voltage supply
⊥	Ground
A+	Channel A+
A-	Channel A- (channel A+ inverted)
B+	Channel B+
B-	Channel B- (channel B+ inverted)
R+	Zero pulse (reference signal)
R-	Zero pulse inverted
nE+	System OK+ / error output
nE-	System OK- / error output inverted
SP+ <sup>2)</sup>	DSL_OUT1 / speed switch (Open-Collector or Solid State Relay)
SP- <sup>2)</sup>	DSL_OUT2 / speed switch (0 V or Solid State Relay)
SA <sup>2)</sup>	RS485+ / programming interface
SB <sup>2)</sup>	RS485- / programming interface

### Incremental - Output signals

Version with additional incremental output at positive rotating direction

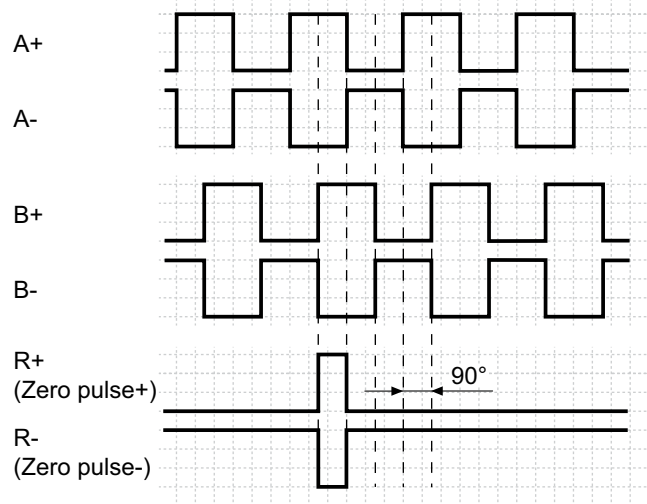

### Speed switch/incremental - Terminal assignment terminal box

View B<sup>1)</sup>

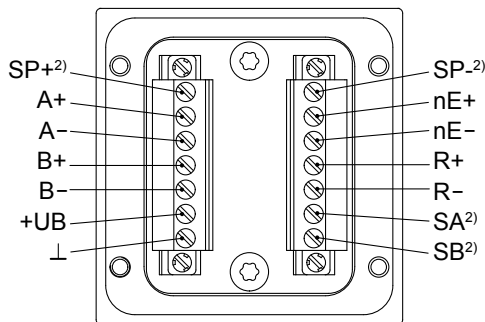

### Speed switch - Switching characteristics

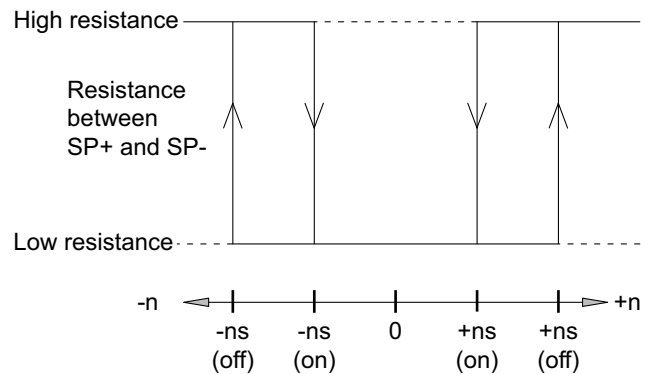

- n = Speed
- +ns (on) = Activation speed at shaft rotation in positive rotating direction<sup>1)</sup>.
- +ns (off) = Deactivation speed at shaft rotation in positive rotating direction<sup>1)</sup>.
- ns (on) = Activation speed at shaft rotation in negative rotating direction<sup>1)</sup>.
- ns (off) = Deactivation at shaft rotation in negative rotating direction<sup>1)</sup>.

<sup>1)</sup> See dimensions

<sup>2)</sup> Do not use at version without speed switch

# Absolute encoders - bus interfaces

Blind / through hollow shaft or cone shaft (1:10)

CANopen® / 13 bit ST / 16 bit MT / Speed switch

## HMG10 - CANopen®

### Dimensions

#### Blind hollow shaft and cone shaft with radial terminal boxes

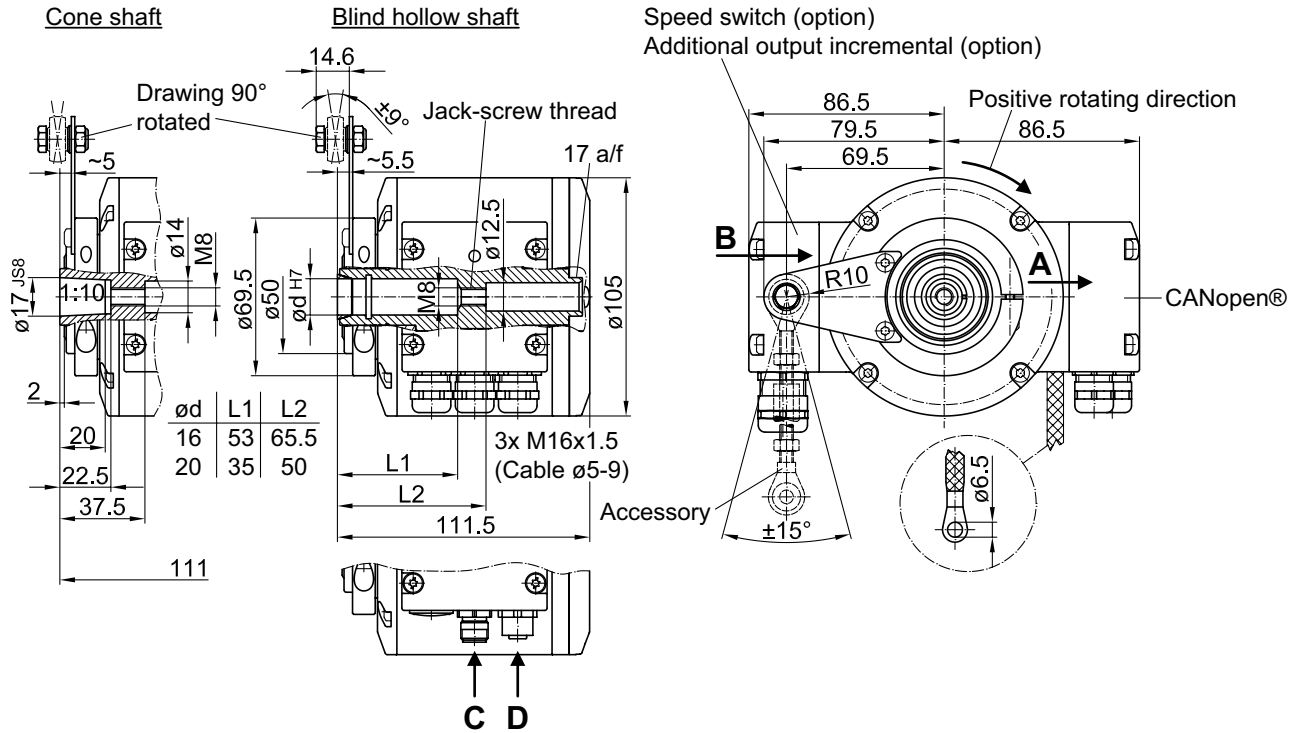

#### Through hollow shaft with radial terminal boxes

